

TAILOR-MADE⁺

STEPS & SPECIAL PIECES

MITRED L SHAPE 45°

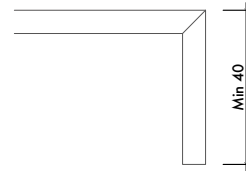
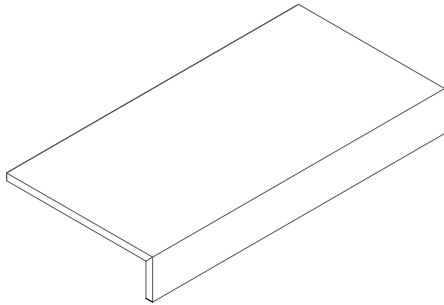

MITRED L SHAPE 45° WITH DRIPSTONE

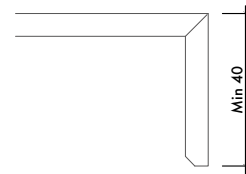
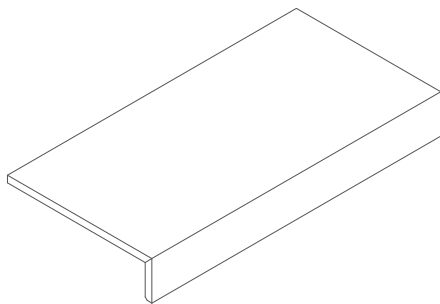

L SHAPE WITH HALF BULLNOSE

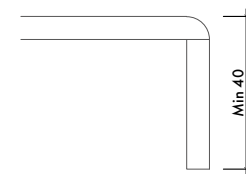
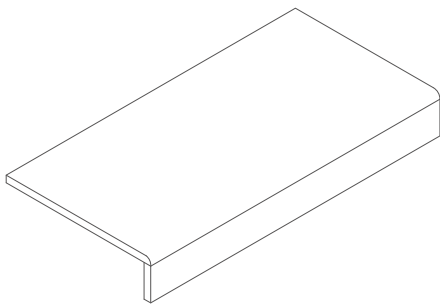

L SHAPE WITH DOUBLE HALF BULLNOSE

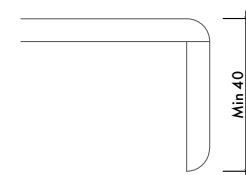
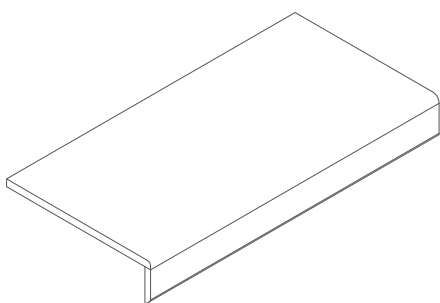

STRAIGHT NOSE

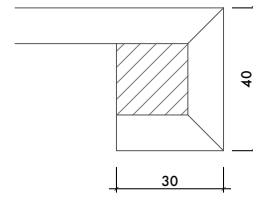
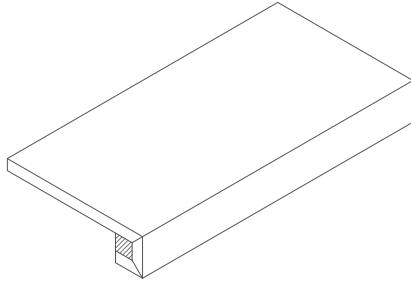

STRAIGHT NOSE WITH DOUBLE SLAT

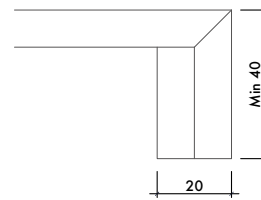
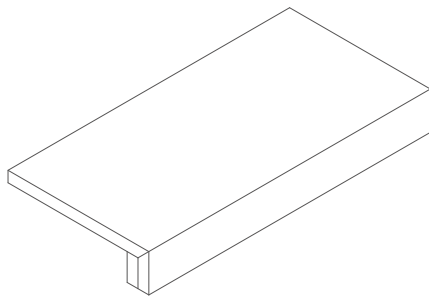

STRAIGHT NOSE WITH DOUBLE HALF BULLNOSE

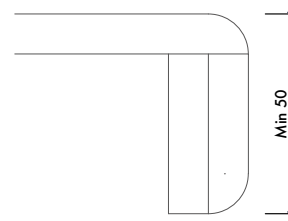
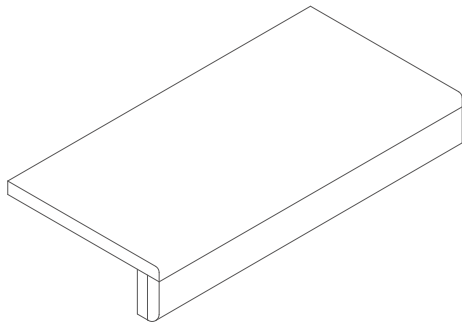

OBLIQUE NOSE

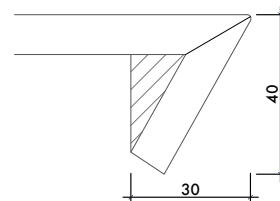
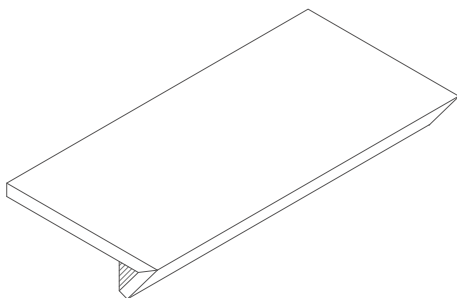

DOUBLE STRAIGHT NOSE

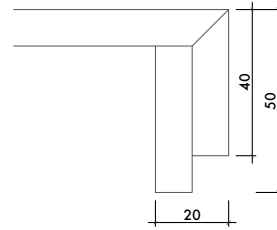
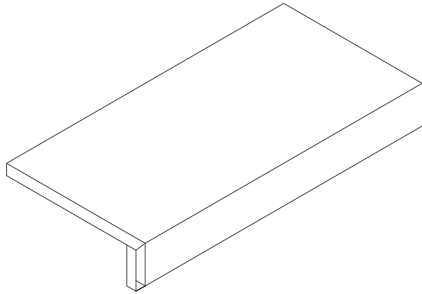

TREAD AND RISER

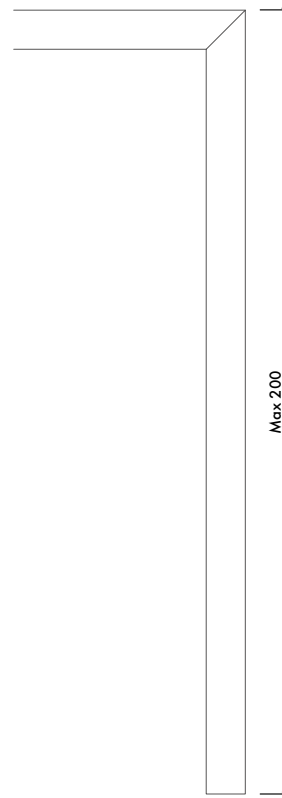
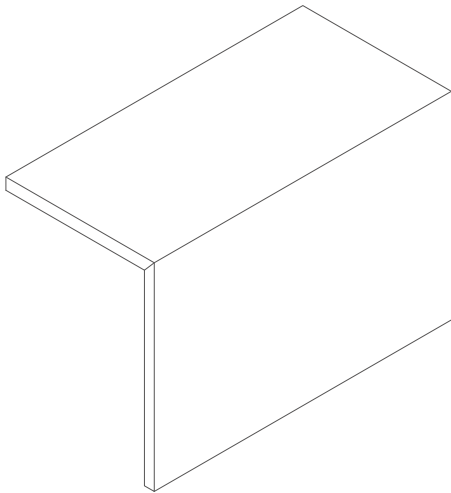

20MM BULLNOSE

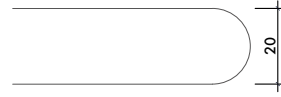
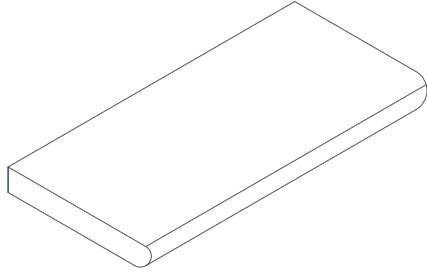

20MM POLISHED NOSE

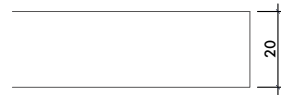
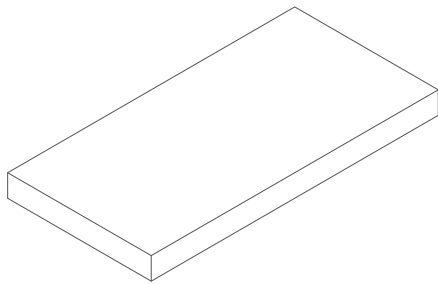

20MM POLISHED BULLNOSE WITH DRIPSTONE

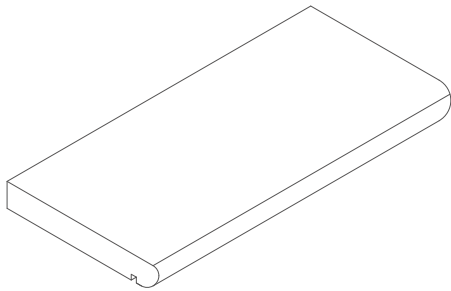

20MM POLISHED NOSE WITH DRIPSTONE

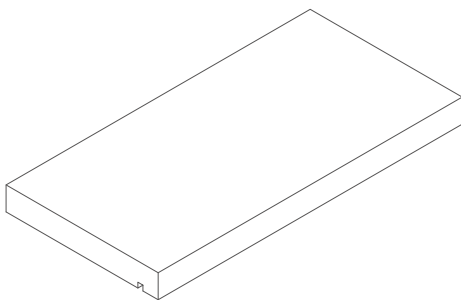

20MM HALF BULLNOSE

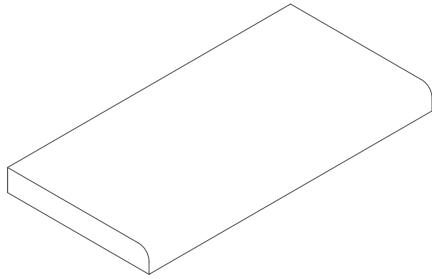

20MM MITRED L SHAPE 45°

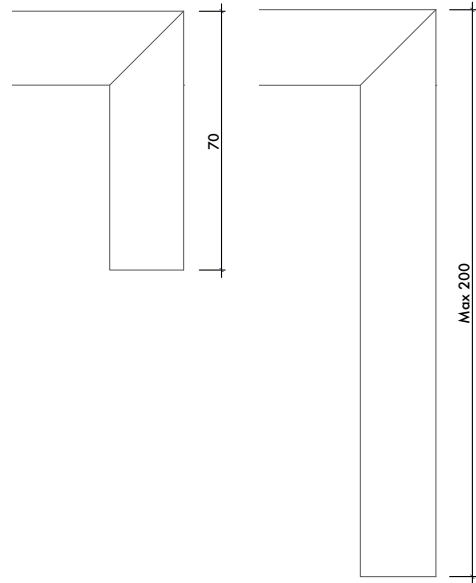
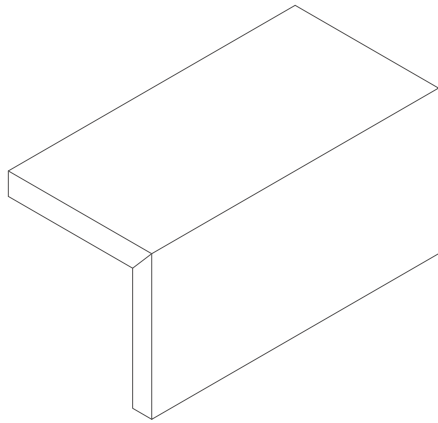

20MM MITRED L SHAPE 45° WITH DRIPSTONE

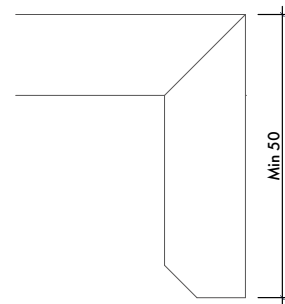
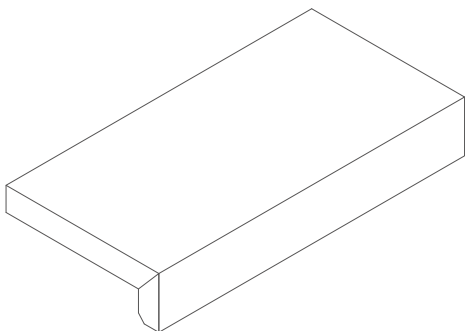

HALF BULLNOSE

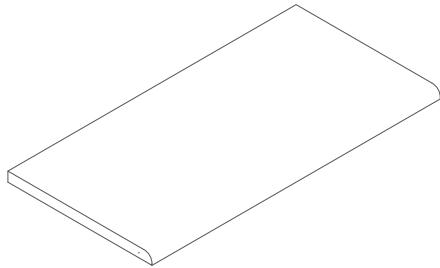

BEVELLED SKIRTING

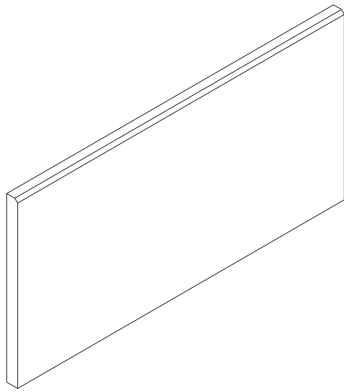

HALF BULLNOSE SKIRTING

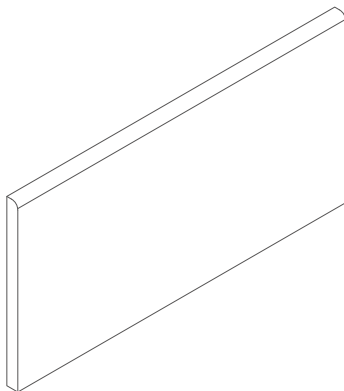

ANTI-SLIP GROOVES (3, 4 OR 5 GROOVES PER STEP)

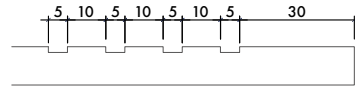
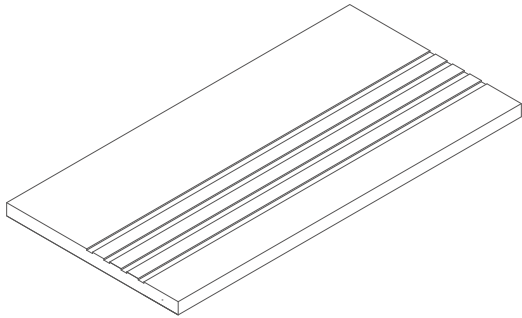

ANTI-SLIP GROOVES WITH HALFBULL NOSE

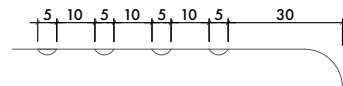
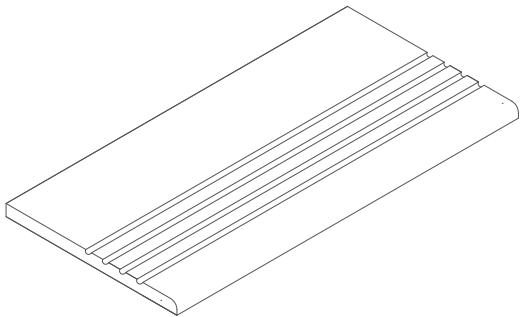

BULLNOSE ON DOUBLE TILE

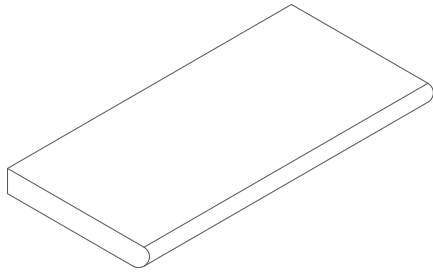

HALF BULLNOSE ON DOUBLE TILE

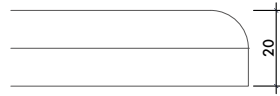
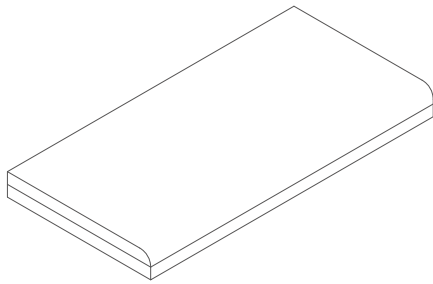

BULLNOSE ON PARTIAL DOUBLE TILE

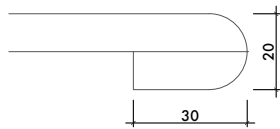
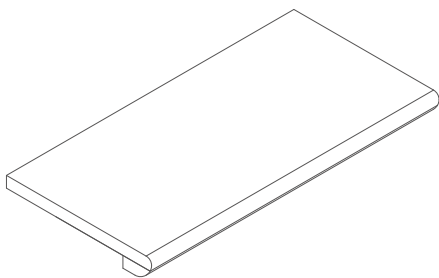

STRAIGHT EDGE 20MM

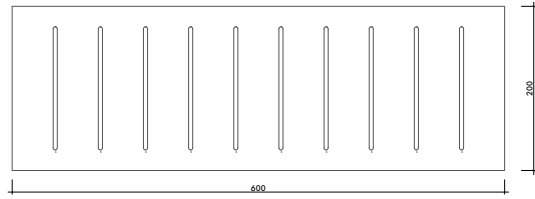
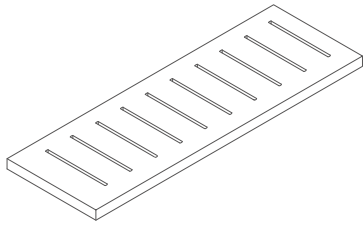

LEFT CORNER 20MM

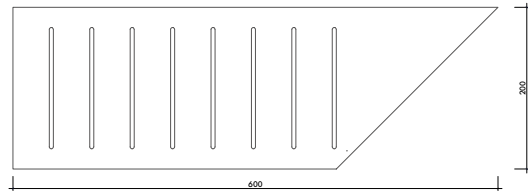
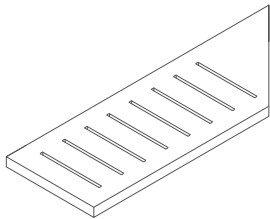

RIGHT CORNER 20MM

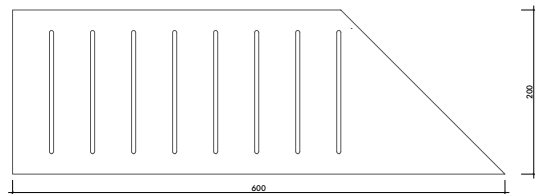
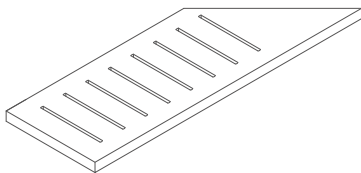

AUTHORISED PARTNERS